

FRONT

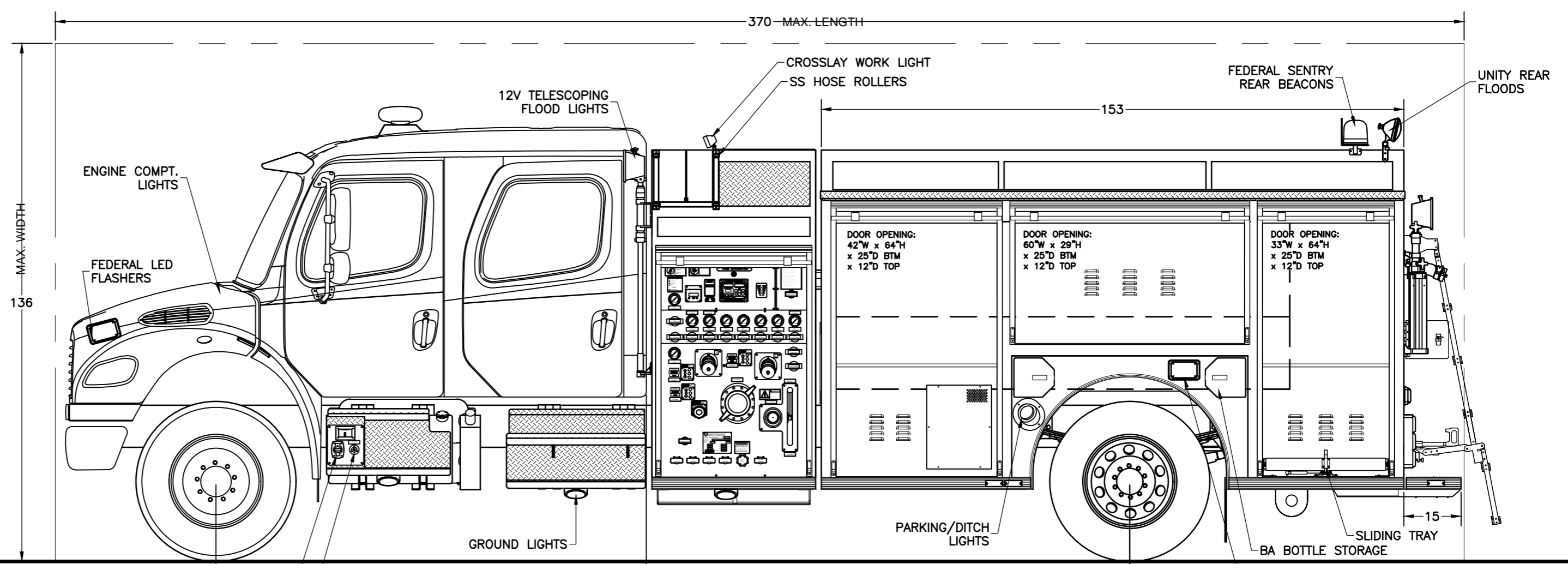

LEFT SIDE

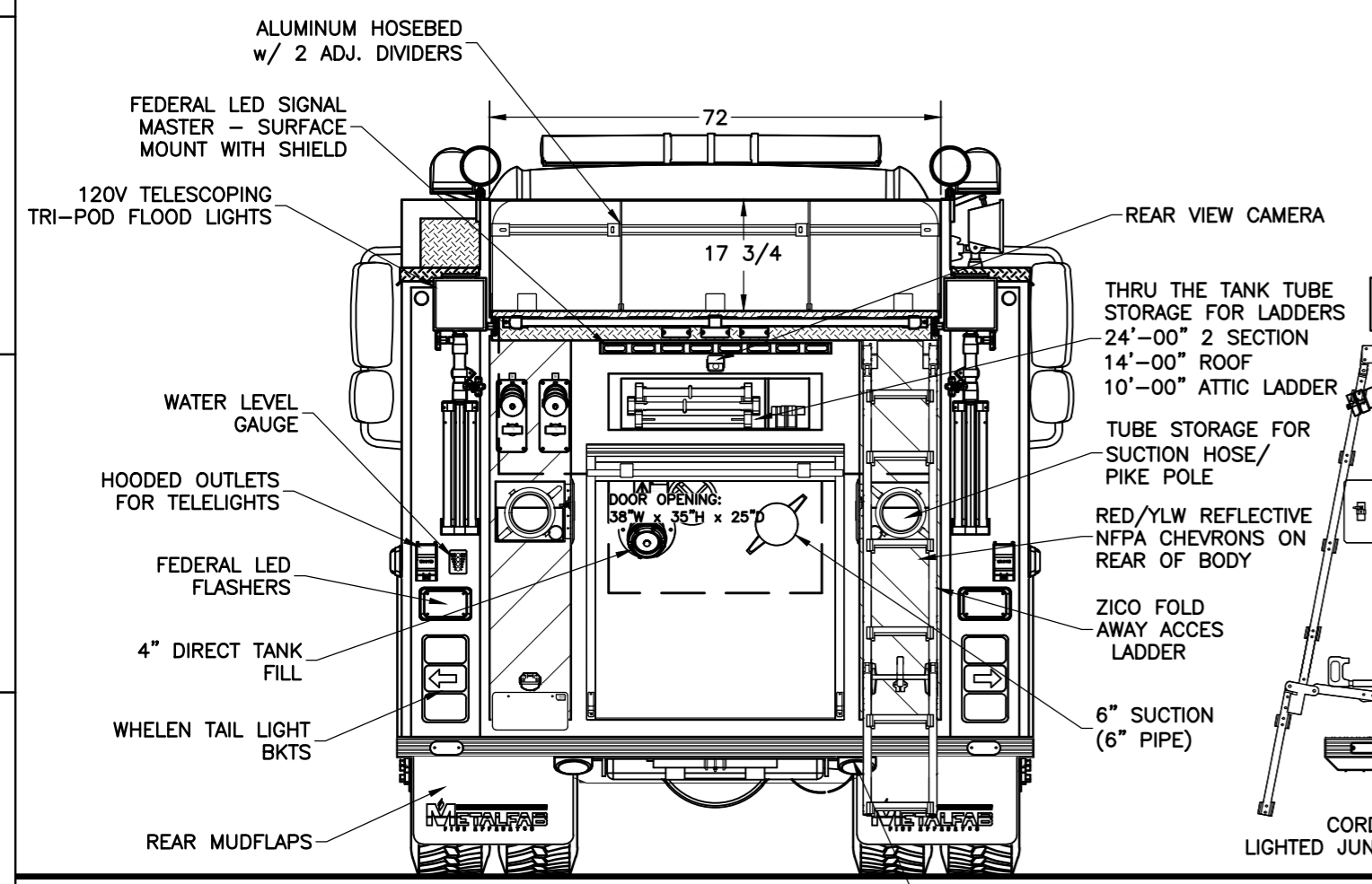

REAR

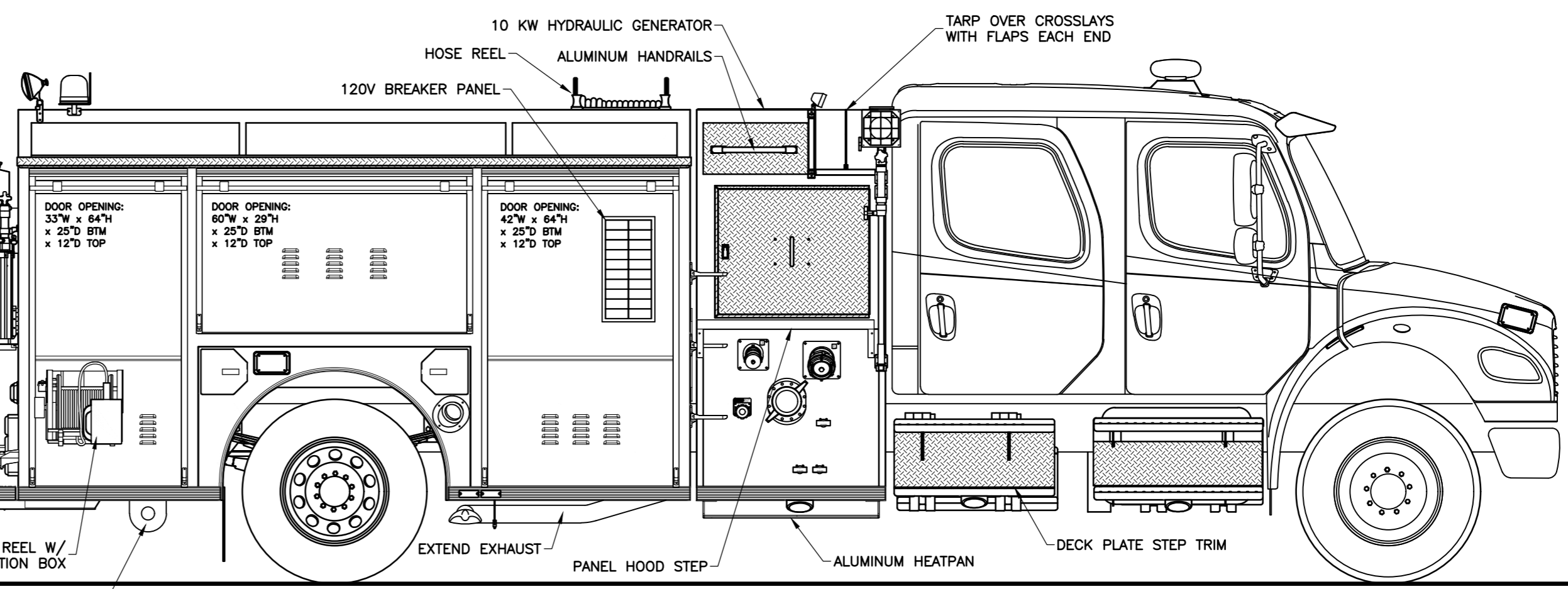

RIGHT SIDE

CHASSIS: FREIGHTLINER M2 106 4 DOOR  
PUMP: HALE QMAX 1500 IGPM  
TANK: 800 Imp. Gal. POLYPROPYLENE  
FOAM: N/A

SUCTION: 1 - 6" LEFT (ELEC MIV)  
1 - 6" RIGHT (ELEC MIV)  
1 - 6" REAR (ELEC MIV) 4" PIPE  
1 - 3" TANK TO PUMP  
1 - 2 1/2" LEFT

DISCHARGES: 1 - 4" RIGHT  
2 - 2 1/2" LEFT  
1 - 2 1/2" RIGHT  
1 - 2 1/2" CROSSLAY  
2 - 2 1/2" REAR  
1 - 2" TANK FILL

1 - 1 1/2" CROSSLAY  
1 - 1" HOSE REEL

| REV | DESCRIPTION                 | APVD BY | DATE     |
|-----|-----------------------------|---------|----------|
| 1   | UPDATE TO SHOP ORDER REVIEW | ---     | 09.10.13 |

REVISIONS

GUYSBOROUGH FIRE DEPARTMENT

JOB No. PROPOSAL  
DRAWN BY T CULLINS  
DATE 05-21-13

METALFAB LTD.  
847 CENTRAL ST. CENTREVILLE  
NB. CANADA E7K 2E8

TITLE GENERAL ARRANGEMENT

DRAWING NO. FT-10521

REV 0

-ALL ALUMINUM CONSTRUCTION - ALL DIMENSIONS ARE IN INCHES & APPROXIMATE